

$\frac{7}{8}$ " - $4\frac{1}{2}$ "
O.D.

AB SERIES WITH BEARING

- Features :*
- Similar to 'A' Series expanders (Pg. 66)
 - Bearing reduces frictional build up for smoother expanding cycles.
 - Bearing increases useful life of tool.
 - Use - High productivity tool used where flaring of tubes is not needed.

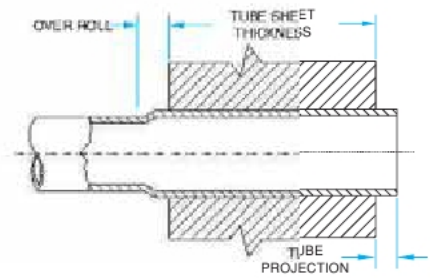
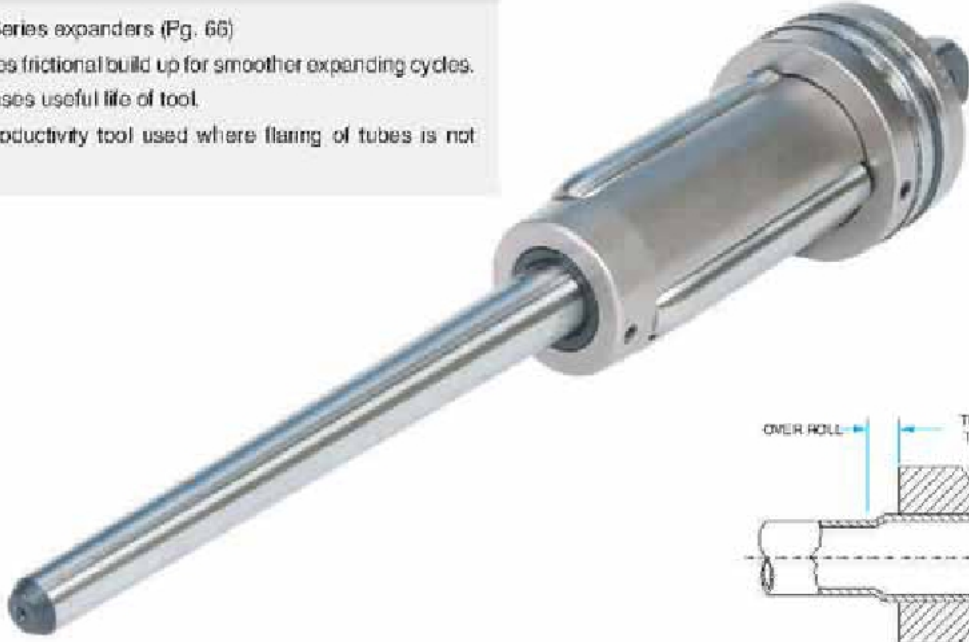

Tube O.D.	Tube Thickness		Tube O.D.	Tube Thickness		Minimum I.D. Tool Enters		Maximum Expansion Of Tool		Tube Expander Model Number Tube Sheet Thickness Range				
	inch	bwg		inch	bwg	inch	mm	inch	mm	inch	1/2" To 7/8"	3/4" To 1.1/8"	1.1/8" To 1.5/8"	1.5/8" To 2.1/8"
7/8	15	.072	1	10	.134	18.1	.712	20.4	.803	AB-31/2	AB-31/3	-	-	-
7/8	16	.065				18.4	.724	20.7	.814	AB-32/2	AB-32/3	-	-	-
7/8	17	.058	1	11	.120	18.8	.740	21.1	.830	AB-33/2	AB-33/3	-	-	-
7/8	18	.049	1	12	.109	19.4	.763	21.6	.850	AB-34/2	AB-34/3	-	-	-
7/8	19 & 20	.042 & .035	1.1/8	8	.165	19.7	.775	22.3	.877	AB-35/2	AB-35/3	-	-	-
1	13	.095				20.1	.791	22.4	.881	AB-36/2	AB-36/3	-	-	-
1	14	.083	1.1/8	9	.148	20.6	.811	23.1	.909	AB-37/2	AB-37/3	AB-37/4	-	-
1	15 & 16	.072 & .065	1.1/8	10	.134	21.3	.838	23.8	.937	AB-38/2	AB-38/3	AB-38/4	-	-
1	17 & 18	.058 & .048	1.1/8	11	.120	22.0	.866	24.5	.964	AB-39/2	AB-39/3	AB-39/4	-	-
1	19 & 20	.042 & .035	1.1/8	12	.109	22.4	.881	25.0	.984	AB-40/2	AB-40/3	AB-40/4	-	-
1.1/4	8	.165	1.1/8	13	.095	23.3	.917	25.9	1.019	AB-41/2	AB-41/3	AB-41/4	-	-
1.1/4	9	.148	1.1/8	14	.083	23.8	.937	26.5	1.043	AB-42/2	AB-42/3	AB-42/4	-	-
1.1/4	10	.134	1.1/8	15 & 16	.072 & .065	24.4	.960	27.2	1.070	AB-43/2	AB-43/3	AB-43/4	-	-
1.1/4	11	.120				25.2	.992	28.0	1.102	AB-44/2	AB-44/3	AB-44/4	-	-
1.1/4	12	.109				25.7	1.011	28.5	1.122	AB-45/2	AB-45/3	AB-45/4	-	-
1.1/4	13	.095	1.3/8	8	.165	26.1	1.027	28.8	1.133	AB-46/2	AB-46/3	AB-46/4	-	-
1.1/4	14	.083				26.4	1.039	29.2	1.149	AB-47/2	AB-47/3	AB-47/4	-	-
1.1/4	15	.072	1.3/8	9	.148	26.9	1.059	29.7	1.169	AB-48/2	AB-48/3	AB-48/4	-	-
1.1/4	16	.065	1.3/8	10	.134	27.6	1.086	30.4	1.196	AB-49/2	AB-49/3	AB-49/4	AB-49/5	AB-49/6
1.1/2	7	.180	1.3/8	11	.120	28.3	1.114	31.2	1.228	AB-50/2	AB-50/3	AB-50/4	AB-50/5	AB-50/6
1.1/2	8	.165	1.3/8	12	.109	28.8	1.133	31.7	1.248	AB-51/2	AB-51/3	AB-51/4	AB-51/5	AB-51/6
1.1/2	9	.148	1.3/8	13 & 14	.095 & .083	29.5	1.161	33.4	1.314	AB-52/2	AB-52/3	AB-52/4	AB-52/5	AB-52/6
1.1/2	10	.134	1.3/8	15 & 16	.072 & .065	30.0	1.181	34.1	1.342	AB-53/2	AB-53/3	AB-53/4	AB-53/5	AB-53/6
1.1/2	11 & 12	.120 & .109				30.6	1.204	34.8	1.370	AB-54/2	AB-54/3	AB-54/4	AB-54/5	AB-54/6
1.1/2	13	.095	1.3/4	5	.220	31.4	1.236	35.6	1.401	AB-55/2	AB-55/3	AB-55/4	AB-55/5	AB-55/6
1.1/2	14 & 15	.083 & .072	1.3/4	6	.203	32.6	1.283	36.8	1.448	AB-56/2	AB-56/3	AB-56/4	AB-56/5	AB-56/6
			1.3/4	7	.180	33.4	1.314	38.1	1.500	AB-57/2	AB-57/3	AB-57/4	AB-57/5	AB-57/6
			1.3/4	8	.165	34.2	1.346	38.7	1.523	AB-58/2	AB-58/3	AB-58/4	AB-58/5	AB-58/6
2	3	.259	1.3/4	9 & 10	.148 & .134	35.0	1.377	40.6	1.598	AB-59/2	AB-59/3	AB-59/4	AB-59/5	AB-59/6
2	4	.238	1.3/4	11 & 12	.120 & .109	36.6	1.440	42.2	1.661	AB-60/2	AB-60/3	AB-60/4	AB-60/5	AB-60/6
2	5 & 6	.220 & .203	1.3/4	13 & 14	.095 & .083	38.2	1.503	43.8	1.712	AB-61/2	AB-61/3	AB-61/4	AB-61/5	AB-61/6
2	7 & 8	.180 & .165	1.3/4	15 & 16	.072 & .065	39.8	1.566	45.4	1.787	AB-62/2	AB-62/3	AB-62/4	AB-62/5	AB-62/6
2	9 & 10	.148 & .134	2.1/4	3	.259	41.4	1.629	47.0	1.850	AB-63/2	AB-63/3	AB-63/4	AB-63/5	AB-63/6
2	11 - 13	.120 - .095	2.1/4	4	.238	42.9	1.688	49.5	1.948	AB-64/2	AB-64/3	AB-64/4	AB-64/5	AB-64/6
2	14 - 16	.083 - .065	2.1/4	6 & 7	.203 & .180	44.5	1.751	51.1	2.011	AB-65/2	AB-65/3	AB-65/4	AB-65/5	AB-65/6
2	17 & 18	.058 & .049	2.1/4	8 & 9	.165 & .148	46.1	1.814	52.7	2.074	AB-66/2	AB-66/3	AB-66/4	AB-66/5	AB-66/6

AB SERIES WITH BEARING

7/8" - 4 1/2"
O.D.

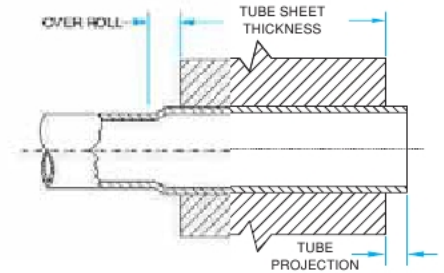

Spare Rollers Set Model Number Tube Sheet Thickness Range					Mandrel Square Drive Size inch	Drum Mandrel Model Number
1/2" To 7/8"	3/4" To 1 1/8"	1 1/8" To 1 5/8"	1 5/8" To 2 1/8"	2 1/8" To 2 5/8"		
15-2-RS	15-3-RS	-	-	-	3/8	DMB-11
15-2-RS	15-3-RS	-	-	-	3/8	DMB-12
16-2-RS	16-3-RS	-	-	-	3/8	DMB-12
20-2-RS	20-3-RS	-	-	-	3/8	DMB-12
17-2-RS	17-3-RS	-	-	-	3/8	DMB-13
18-2-RS	18-3-RS	-	-	-	3/8	DMB-12
18-2-RS	18-3-RS	18-4-RS	-	-	3/8	DMB-13
19-2-RS	19-3-RS	19-4-RS	-	-	3/8	DMB-13
21-2-RS	21-3-RS	21-4-RS	-	-	3/8	DMB-13
21-2-RS	21-3-RS	21-4-RS	-	-	3/8	DMB-14
22-2-RS	22-3-RS	22-4-RS	-	-	3/8	DMB-14
23-2-RS	23-3-RS	23-4-RS	-	-	1/2	DMB-15
24-2-RS	24-3-RS	24-4-RS	-	-	1/2	DMB-15
26-2-RS	26-3-RS	26-4-RS	-	-	1/2	DMB-16
27-2-RS	27-3-RS	27-4-RS	-	-	1/2	DMB-16
31-2-RS	31-3-RS	31-4-RS	-	-	1/2	DMB-16
28-2-RS	28-3-RS	28-4-RS	-	-	1/2	DMB-17
29-2-RS	29-3-RS	29-4-RS	-	-	1/2	DMB-17
30-2-RS	30-3-RS	30-4-RS	30-5-RS	30-6-RS	1/2	DMB-17
30-2-RS	30-3-RS	30-4-RS	30-5-RS	30-6-RS	1/2	DMB-18
32-2-RS	32-3-RS	32-4-RS	32-5-RS	32-6-RS	1/2	DMB-18
28-2-RS	28-3-RS	28-4-RS	28-5-RS	28-6-RS	1/2	DMB-20
29-2-RS	29-3-RS	29-4-RS	29-5-RS	29-6-RS	1/2	DMB-20
30-2-RS	30-3-RS	30-4-RS	30-5-RS	30-6-RS	1/2	DMB-20
33-2-RS	33-3-RS	33-4-RS	33-5-RS	33-6-RS	1/2	DMB-20
32-2-RS	32-3-RS	32-4-RS	32-5-RS	32-6-RS	1/2	DMB-21
36-2-RS	36-3-RS	36-4-RS	36-5-RS	36-6-RS	1/2	DMB-21
37-2-RS	37-3-RS	37-4-RS	37-5-RS	37-6-RS	1/2	DMB-21
33-2-RS	33-3-RS	33-4-RS	33-5-RS	33-6-RS	3/4	DMB-22
37-2-RS	37-3-RS	37-4-RS	37-5-RS	37-6-RS	3/4	DMB-22
38-2-RS	38-3-RS	38-4-RS	38-5-RS	38-6-RS	3/4	DMB-22
39-2-RS	39-3-RS	39-4-RS	39-5-RS	39-6-RS	3/4	DMB-22
40-2-RS	40-3-RS	40-4-RS	40-5-RS	40-6-RS	3/4	DMB-22
40-2-RS	40-3-RS	40-4-RS	40-5-RS	40-6-RS	3/4	DMB-23
41-2-RS	41-3-RS	41-4-RS	41-5-RS	41-6-RS	3/4	DMB-23
42-2-RS	42-3-RS	42-4-RS	42-5-RS	42-6-RS	3/4	DMB-23

$\frac{7}{8}$ " - $4\frac{1}{2}$ "
O.D.

AB SERIES WITH BEARING

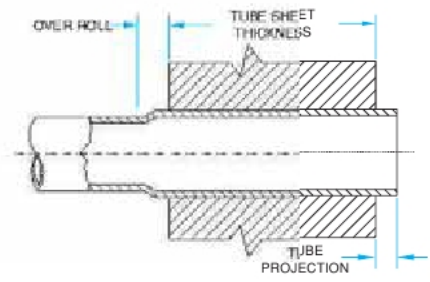

Tube O.D.	Tube Thickness		Tube O.D.	Tube Thickness		Minimum I.D. Tool Enters		Maximum Expansion Of Tool		Tube Expander Model Number Tube Sheet Thickness Range				
	inch	bwg		inch	bwg	inch	mm	inch	mm	inch	1/2" To 7/8"	3/4" To 1.1/8"	1.1/8" To 1.5/8"	1.5/8" To 2.1/8"
2.1/2	3	.259	2.1/4	10 & 11	.134 & .120	47.7	1.877	54.3	2.137	AB-67/2	AB-67/3	AB-67/4	AB-67/5	AB-67/6
2.1/2	4 & 5	.238 & .220	2.1/4	12 & 13	.109 & .095	49.3	1.940	55.9	2.200	AB-68/2	AB-68/3	AB-68/4	AB-68/5	AB-68/6
2.1/2	6 & 7	.203 & .180	2.1/4	14 - 16	.083 - .065	50.8	2.000	57.8	2.275	AB-69/2	AB-69/3	AB-69/4	AB-69/5	AB-69/6
2.1/2	8 & 9	.165 & .148	2.3/4	3	.259	52.4	2.062	59.4	2.338	AB-70/2	AB-70/3	AB-70/4	AB-70/5	AB-70/6
2.1/2	10 & 11	.134 & .120	2.3/4	4	.238	54.0	2.125	61.0	2.401	AB-71/2	AB-71/3	AB-71/4	AB-71/5	AB-71/6
2.1/2	12 - 14	.109 - .083	2.3/4	5 & 6	.220 & .203	55.6	2.188	64.0	2.519	AB-72/2	AB-72/3	AB-72/4	AB-72/5	AB-72/6
2.1/2	15 & 16	.072 & .065	2.3/4	7 & 8	.180 & .165	57.2	2.251	65.6	2.582	AB-73/2	AB-73/3	AB-73/4	AB-73/5	AB-73/6
3	3	.259	2.3/4	9 & 10	.148 & .134	58.6	2.307	67.0	2.637	AB-74/2	AB-74/3	AB-74/4	AB-74/5	AB-74/6
3	4	.238	2.3/4	11 - 13	.120 - .095	60.4	2.377	68.8	2.708	AB-75/2	AB-75/3	AB-75/4	AB-75/5	AB-75/6
3	5 & 6	.220 & .203	2.3/4	14 - 16	.083 - .065	62.2	2.448	70.4	2.771	AB-76/2	AB-76/3	AB-76/4	AB-76/5	AB-76/6
3	7 & 8	.180 & .165				63.6	2.503	72.0	2.834	AB-77/2	AB-77/3	AB-77/4	AB-77/5	AB-77/6
3	9 & 10	.148 & .134	3.1/4	3	.259	65.0	2.559	73.4	2.889	AB-78/2	AB-78/3	AB-78/4	AB-78/5	AB-78/6
3	11 - 13	.120 - .095	3.1/4	4	.238	66.6	2.622	75.0	2.952	AB-79/2	AB-79/3	AB-79/4	AB-79/5	AB-79/6
3	14 - 16	.083 - .065	3.1/4	5 & 6	.220 & .203	68.3	2.688	76.9	3.027	AB-80/2	AB-80/3	AB-80/4	AB-80/5	AB-80/6
3.1/2	2	.284	3.1/4	7 & 8	.180 & .165	69.9	2.751	78.5	3.090	AB-81/2	AB-81/3	AB-81/4	AB-81/5	AB-81/6
3.1/2	3	.259	3.1/4	9 & 10	.148 & .134	71.5	2.814	80.1	3.153	AB-82/2	AB-82/3	AB-82/4	AB-82/5	AB-82/6
3.1/2	4	.238	3.1/4	11 - 13	.120 - .095	73.1	2.877	81.7	3.216	AB-83/2	AB-83/3	AB-83/4	AB-83/5	AB-83/6
3.1/2	5 & 6	.220 & .203	3.1/4	14 - 16	.083 - .065	74.6	2.937	84.2	3.314	AB-84/2	AB-84/3	AB-84/4	AB-84/5	AB-84/6
3.1/2	7 & 8	.180 & .165	3.3/4	2	.284	76.2	3.000	85.5	3.366	AB-85/2	AB-85/3	AB-85/4	AB-85/5	AB-85/6
3.1/2	9 - 11	.148 - .120	3.3/4	3	.259	77.8	3.062	87.4	3.440	AB-86/2	AB-86/3	AB-86/4	AB-86/5	AB-86/6
3.1/2	12 - 16	.109 - .065	3.3/4	4	.238	79.4	3.125	89.0	3.503	AB-87/2	AB-87/3	AB-87/4	AB-87/5	AB-87/6
			3.3/4	5 & 6	.220 & .203	81.0	3.188	90.6	3.566	AB-88/2	AB-88/3	AB-88/4	AB-88/5	AB-88/6
4	2	.284	3.3/4	7 & 8	.180 & .165	82.6	3.251	92.2	3.629	AB-89/2	AB-89/3	AB-89/4	AB-89/5	AB-89/6
4	3	.259	3.3/4	9 & 10	.148 & .134	84.2	3.314	93.8	3.692	AB-90/2	AB-90/3	AB-90/4	AB-90/5	AB-90/6
4	4	.238	3.3/4	11 - 13	.120 - .095	85.8	3.377	96.2	3.787	AB-91/2	AB-91/3	AB-91/4	AB-91/5	AB-91/6
4	5 & 6	.220 & .203	3.3/4	14 - 16	.083 - .065	87.4	3.440	97.8	3.850	AB-92/2	AB-92/3	AB-92/4	AB-92/5	AB-92/6
4	7 & 8	.180 & .165	4.1/4	2	.284	89.0	3.503	99.4	3.913	AB-93/2	AB-93/3	AB-93/4	AB-93/5	AB-93/6
4	9 - 11	.148 - .120	4.1/4	3	.259	90.4	3.559	100.8	3.968	AB-94/2	AB-94/3	AB-94/4	AB-94/5	AB-94/6
4	12 - 16	.109 - .065	4.1/4	4	.238	92.0	3.622	102.4	4.031	AB-95/2	AB-95/3	AB-95/4	AB-95/5	AB-95/6
			4.1/4	5 & 6	.220 & .203	93.4	3.677	103.8	4.086	AB-96/2	AB-96/3	AB-96/4	AB-96/5	AB-96/6
4.1/2	2	.284	4.1/4	7 & 8	.180 & .165	95.0	3.740	105.4	4.149	AB-97/2	AB-97/3	AB-97/4	AB-97/5	AB-97/6
4.1/2	3	.259	4.1/4	9 - 11	.148 - .120	96.6	3.803	107.0	4.212	AB-98/2	AB-98/3	AB-98/4	AB-98/5	AB-98/6
4.1/2	4 & 5	.238 & .220	4.1/4	11 - 13	.120 - .095	98.2	3.866	108.6	4.275	AB-99/2	AB-99/3	AB-99/4	AB-99/5	AB-99/6
4.1/2	6 & 7	.203 & .180				101.2	3.984	110.0	4.330	AB-100/2	AB-100/3	AB-100/4	AB-100/5	AB-100/6
4.1/2	8 & 9	.165 & .148				102.8	4.047	111.6	4.393	AB-101/2	AB-101/3	AB-101/4	AB-101/5	AB-101/6
4.1/2	10 - 12	.134 - .109				104.4	4.110	113.2	4.456	AB-102/2	AB-102/3	AB-102/4	AB-102/5	AB-102/6

AB SERIES WITH BEARING

$\frac{7}{8}$ "- $4\frac{1}{2}$ "
O.D.

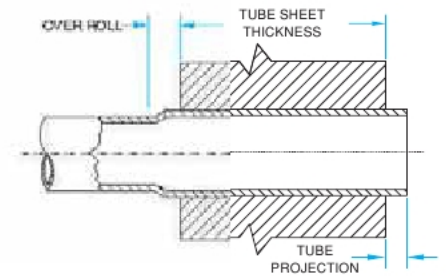

Spare Rollers Set Model Number Tube Sheet Thickness Range					Mandrel Square Drive Size inch	Drum Mandrel Model Number
1/2" To 7/8"	3/4" To 1.1/8"	1.1/8" To 1.5/8"	1.5/8" To 2.1/8"	2.1/8" To 2.5/8"		
43-2-RS	43-3-RS	43-4-RS	43-5-RS	43-6-RS	3/4	DMB-23
44-2-RS	44-3-RS	44-4-RS	44-5-RS	44-6-RS	3/4	DMB-23
43-2-RS	43-3-RS	43-4-RS	43-5-RS	43-6-RS	3/4	DMB-24
44-2-RS	44-3-RS	44-4-RS	44-5-RS	44-6-RS	3/4	DMB-24
45-2-RS	45-3-RS	45-4-RS	45-5-RS	45-6-RS	3/4	DMB-24
47-2-RS	47-3-RS	47-4-RS	47-5-RS	47-6-RS	3/4	DMB-24
46-2-RS	46-3-RS	46-4-RS	46-5-RS	46-6-RS	1	DMB-25
47-2-RS	47-3-RS	47-4-RS	47-5-RS	47-6-RS	1	DMB-25
48-2-RS	48-3-RS	48-4-RS	48-5-RS	48-6-RS	1	DMB-25
49-2-RS	49-3-RS	49-4-RS	49-5-RS	49-6-RS	1	DMB-25
50-2-RS	50-3-RS	50-4-RS	50-5-RS	50-6-RS	1	DMB-25
51-2-RS	51-3-RS	51-4-RS	51-5-RS	51-6-RS	1	DMB-25
52-2-RS	52-3-RS	52-4-RS	52-5-RS	52-6-RS	1	DMB-25
51-2-RS	51-3-RS	51-4-RS	51-5-RS	51-6-RS	1	DMB-26
52-2-RS	52-3-RS	52-4-RS	52-5-RS	52-6-RS	1	DMB-26
53-2-RS	53-3-RS	53-4-RS	53-5-RS	53-6-RS	1	DMB-26
54-2-RS	54-3-RS	54-4-RS	54-5-RS	54-6-RS	1	DMB-26
54-2-RS	54-3-RS	54-4-RS	54-5-RS	54-6-RS	1	DMB-27
55-2-RS	55-3-RS	55-4-RS	55-5-RS	55-6-RS	1	DMB-27
56-2-RS	56-3-RS	56-4-RS	56-5-RS	56-6-RS	1	DMB-27
57-2-RS	57-3-RS	57-4-RS	57-5-RS	57-6-RS	1	DMB-27
58-2-RS	58-3-RS	58-4-RS	58-5-RS	58-6-RS	1	DMB-27
59-2-RS	59-3-RS	59-4-RS	59-5-RS	59-6-RS	1	DMB-27
60-2-RS	60-3-RS	60-4-RS	60-5-RS	60-6-RS	1	DMB-27
59-2-RS	59-3-RS	59-4-RS	59-5-RS	59-6-RS	1	DMB-28
60-2-RS	60-3-RS	60-4-RS	60-5-RS	60-6-RS	1	DMB-28
61-2-RS	61-3-RS	61-4-RS	61-5-RS	61-6-RS	1	DMB-28
62-2-RS	62-3-RS	62-4-RS	62-5-RS	62-6-RS	1	DMB-28
63-2-RS	63-3-RS	63-4-RS	63-5-RS	63-6-RS	1	DMB-28
62-2-RS	62-3-RS	62-4-RS	62-5-RS	62-6-RS	1	DMB-29
63-2-RS	63-3-RS	63-4-RS	63-5-RS	63-6-RS	1	DMB-29
64-2-RS	64-3-RS	64-4-RS	64-5-RS	64-6-RS	1	DMB-29
63-2-RS	63-3-RS	63-4-RS	63-5-RS	63-6-RS	1	DMB-30
64-2-RS	64-3-RS	64-4-RS	64-5-RS	64-6-RS	1	DMB-30
65-2-RS	65-3-RS	65-4-RS	65-5-RS	65-6-RS	1	DMB-30
66-2-RS	66-3-RS	66-4-RS	66-5-RS	66-6-RS	1	DMB-30

AB SERIES WITH BEARING